

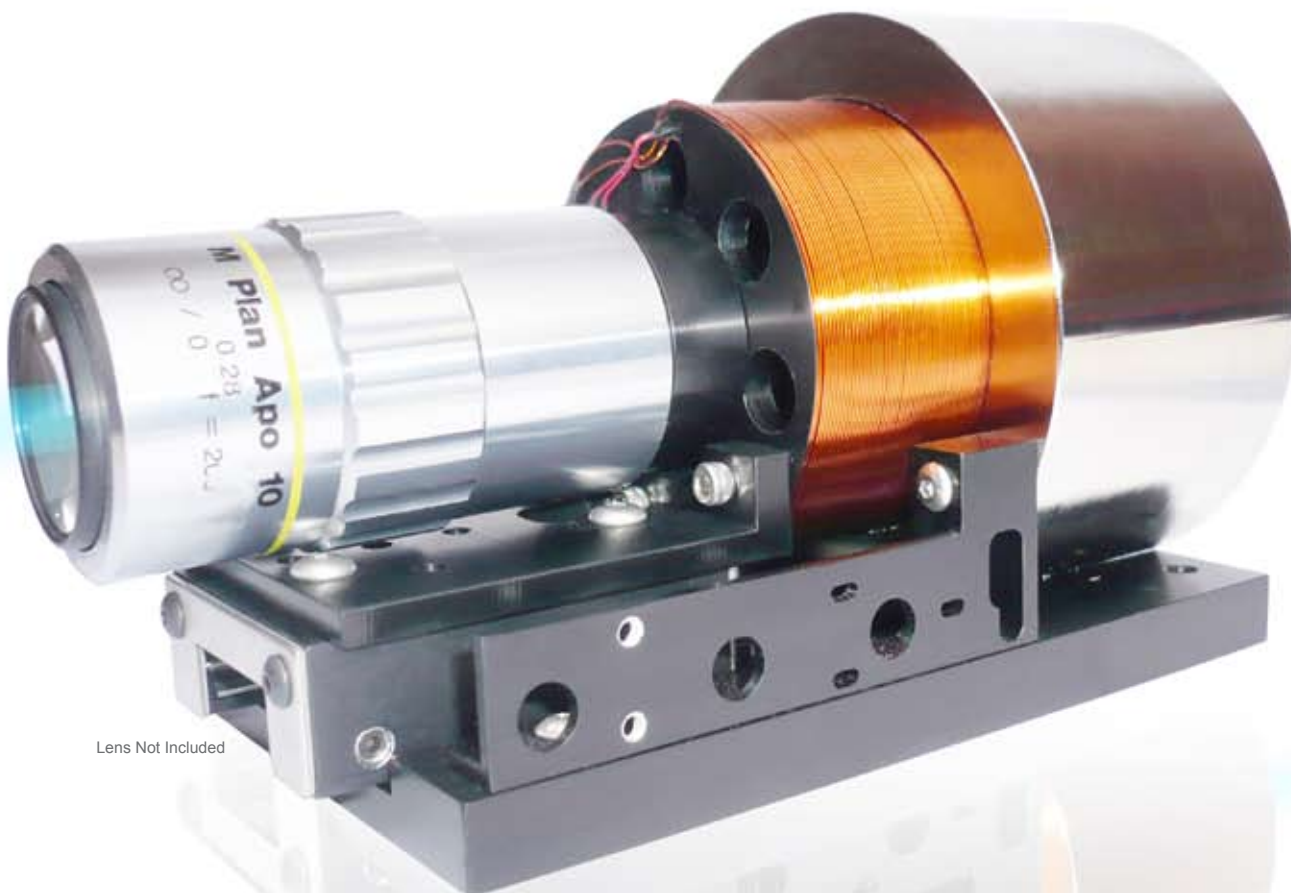

Guide and Capture Light
through the Middle of the Motor.

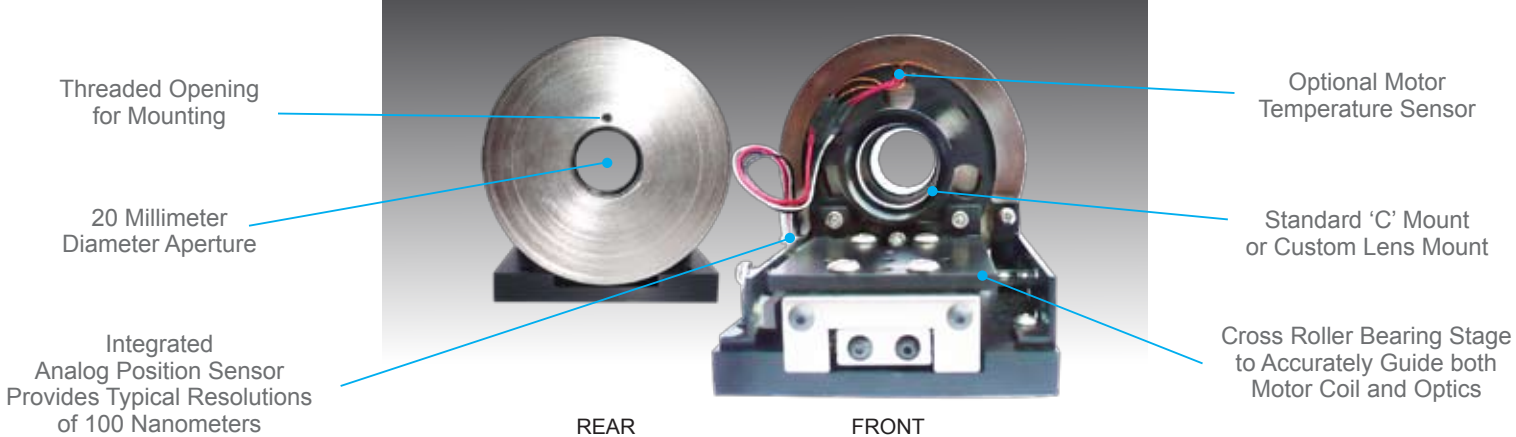

equipMent™ VCS-2020 Voice Coil Stage
solutions



The **VCS-2020 Voice Coil Stage** is a high performance, compact positioning system specifically developed for applications requiring both high precision and high-speed positioning over a short to full 20 millimeter, medium stroke. This system is fully self-contained—including a one axis, cross roller bearing stage, a voice coil actuator, a feedback device, a servo amplifier and a servo controller.



Solid, All Metal Construction Throughout Entire Unit

Integrated English and Metric Mounting

Integrated Lens 'C'-Mount at Motor Center for Tip/Tilt Free Motion

Plug-in Compatibility with SCA814 Servo Amplifier

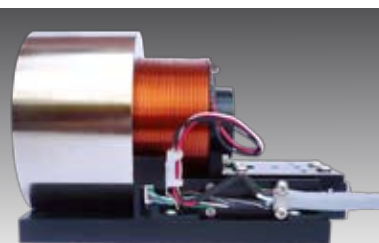
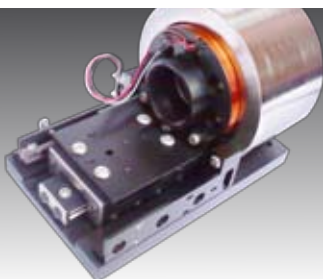
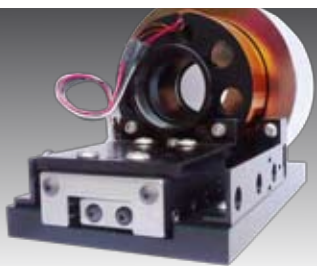



Need New Text

Overview: The LFA-2010 Linear Focus Actuator is ideal for optical focusing and other micro-positioning applications such as scanning interferometry, surface structure analysis, disk drive testing, auto-focus systems, confocal microscopy, biotechnology, and semiconductor test equipment.

Stage: The LFA-2010 is guided along a single axis by a patented flexure design. Flexures produce a compact and light package with zero stiction/friction, ultra-high resolution and exceptional guiding precision. The stage can be oriented in either a vertical or a horizontal position. Multiple sets of mounting holes are included for convenient mounting. A standard 'C' mount is provided on the translator element and optional adapters are available for DIN standard microscope objectives and simple lens.

Voice Coil: The LFA-2010's responsive performance is achieved through a high force, low mass moving voice coil architecture (Voice coil motors produce the least amount of electrical noise of any motor type available today.). Our voice coil motor adds no additional friction to the stage and provides superior responsiveness over micropositioners with conventional screw drives and bearing guide way.

Positioning Feedback Sensor: The LFA-2010 includes a sub-micron resolution linear displacement sensor. Our sensor has high bandwidth and low noise for responsive and precise movements using a frictionless, non-contact optical technology. The compact nature of the system and its extremely low mass, improves system performance.

VCS-2020 Specifications:

Clear Aperture:	20 mm
Range of Motion:	20 mm
Positioning Resolution:	>300 nm
Peak Force:	16 lbs, 10 sec
Max Continuous Force:	4 lbs
Motor Constant:	1.6 lbs/Amp
Coil Resistance:	4.7 Ω
Coil Inductance:	1.1 mH
Non-Linearity:	<±0.5%
Repeatability, Short Term:	100 nm
Repeatability, Long Term:	50 ppm/1000hrs.
Temperature Stability:	±250 nm/°C
Hysteresis:	None
Deadband:	None
Travel Non-Straightness:	<0.5 μm
Dimensions:	70 x 117 x 81 mm
Total Mass:	1.66 kg
Moving Mass:	200 g

LFA-2010 Typical Flexure Spring Rate

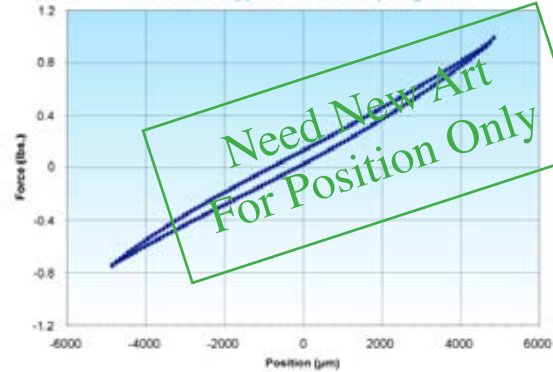

LFA-2010 Dynamic Response

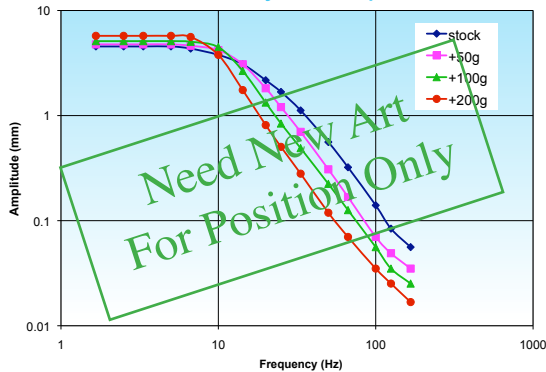

VCS-2020 Typical Position Sensor Nonlinearity

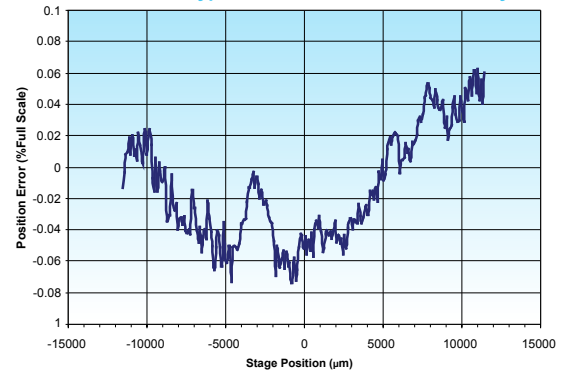

VCS-2020 Typical Motor Force Constant

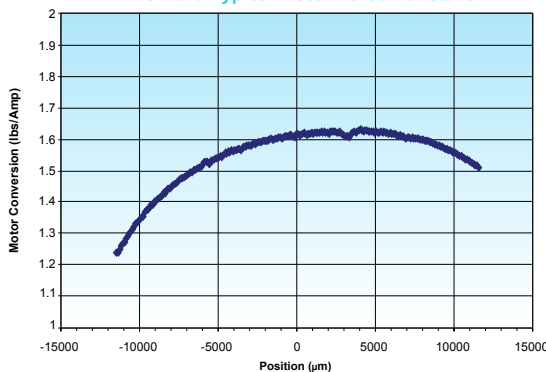

LFA-2010 Typical Position Induced Angular Error

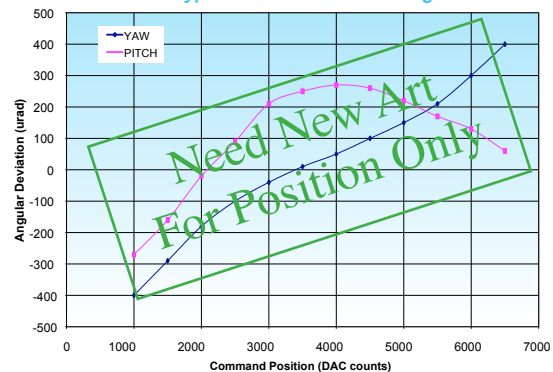

LFA-2010 Interface (Layout Drawings)

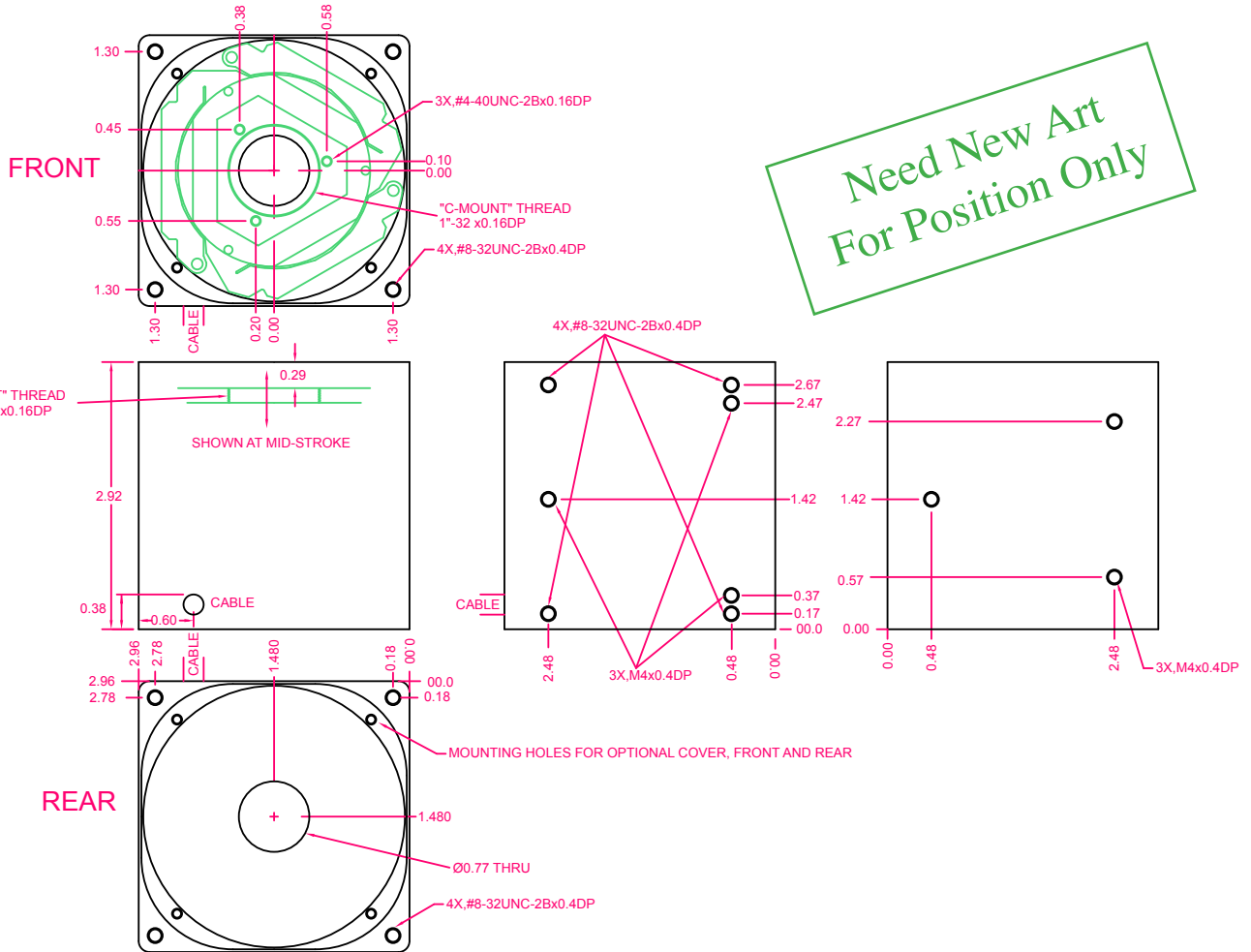

Need New Art For Position Only

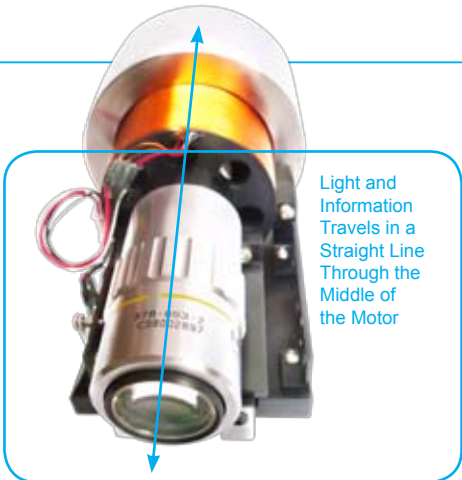

- FEATURES:**
- High Speed Sub-Micron Positioning
 - Compact Packaging
 - Integrated Position Feedback Sensor
 - High Force Generation
 - No Frictional elements
 - Horizontal or Vertical Operation
 - Simple Electrical Interfacing
 - Clean Room Compatibility
 - Patented Technologies
 - Integrated Standard "C-Mount"

Need New Text